

HYDRA RAM[®]

DEMOLITION & RECYCLING EQUIPMENT



FX SERIES



**12 MODELS HYDRAULIC HAMMERS FROM 100 UP TO 7400 KGS
FOR EXCAVATORS FROM 1 ~ 100 TONS**



HYDRA RAM®

DEMOLITION & RECYCLING EQUIPMENT

FX SERIES

- Soundproofed** Less noise (sound proofed housing)
- Vibration Damper** Vibration Damper absorbs recoil energy of the hammer and reduces wear on the excavator
- Bigger Nitrogen chamber** Increases impact energy
- Frequency Valve** Variable stroke frequency
- Bigger control valve** Oversized control valve is 10 to 15% more efficient than other systems. Result: Hammer gets less hot and has greater blow energy
- Auto Lube** Automatic lubrication system (optional)
- Accumulator** Accumulator absorbs peak pressures and increases the efficiency of the hammer = less strain / wear on the hydraulics of the excavator
- Heavy Duty housing** Housing wear parts made of HARDOX @steel
- Retainer pin** Oversized retainer pin ensures a long life
- Piston** Higher impact energy through longer stroke
- Chisel** Longer life due to special hardening process

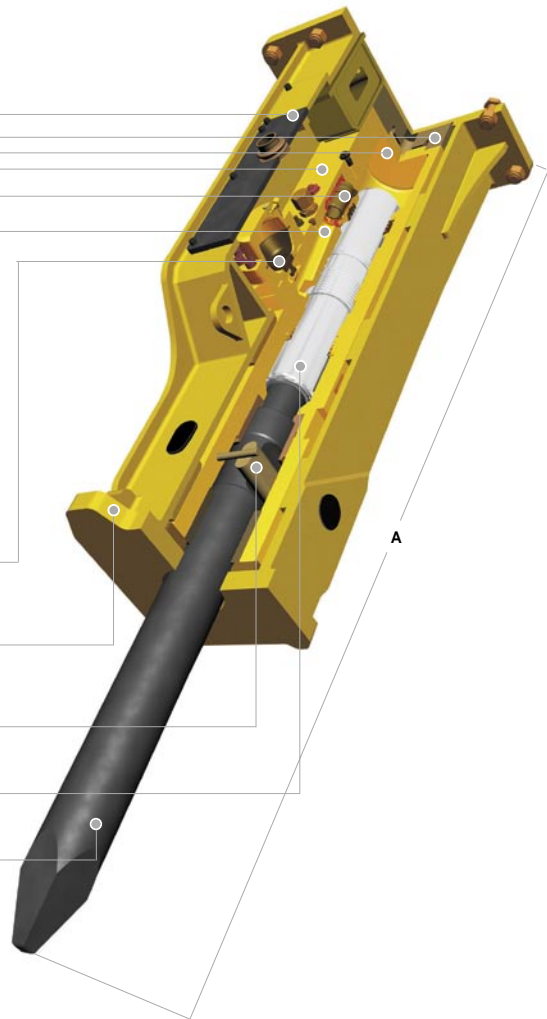

		FX-10	FX-20	FX-30	FX-40	FX-50	FX-70	FX-90	FX-120	FX-160	FX-200	FX-220	FX-340	FX-500	FX-800
(1)	t.	0.8-2.0	1.5-3.0	2-4	3-5	4-7	6-9	7-12	10-16	14-18	16-24	19-26	28-40	42-55	60-100
*	kg.	100	135	160	195	320	410	550	920	1320	1580	1900	2500	4150	7400
A	mm.	1180	1210	1240	1280	1580	1683	1950	2240	2640	2700	2860	3170	3610	4445
	s/pm	700-1200	700-1200	550-1000	500-900	500-800	400-800	400-700	400-700	400-600	400-600	400-600	300-400	250-350	200-400
	bar	80-100	100-120	100-120	110-130	140-160	140-160	140-160	150-170	150-180	160-180	160-180	160-180	160-180	190-210
	bar	120-140	140-160	140-160	150-170	180-200	180-200	180-200	190-210	190-220	200-220	200-220	200-220	200-220	230-250
	l/min.	10-20	15-25	25-40	30-50	35-65	40-70	45-85	80-120	100-140	110-150	130-170	170-230	200-300	290-370
	mm.	36	45	53	60	68	75	90	100	125	135	140	155	175	210

(*) The above mentioned weight is calculated including average connection plate
 (1) Recommended excavator / attachment combination

(DEALER)



MASE TRADING

Machinery / Attachments / Spare parts / Equipment

+31 (0)6 438 132 50 info@masetrading.nl www.masetrading.nl



HYDRA RAM®
 DEMOLITION & RECYCLING EQUIPMENT

HYDRARAM b.v.
 Meander 7
 NL 9231DB SURHUISTERVEEN
 The Netherlands

tel. +31 512-365981
 fax. +31 512-365761
 www.hydraram.com
 info@hydraram.com